



# D rilling



CNC & Automatic Machines  
Multi Purpose Boring  
Slot Mortising  
Counter Sinking & Plug maker

Index  
→

## D irose™ Profile for Rosettes

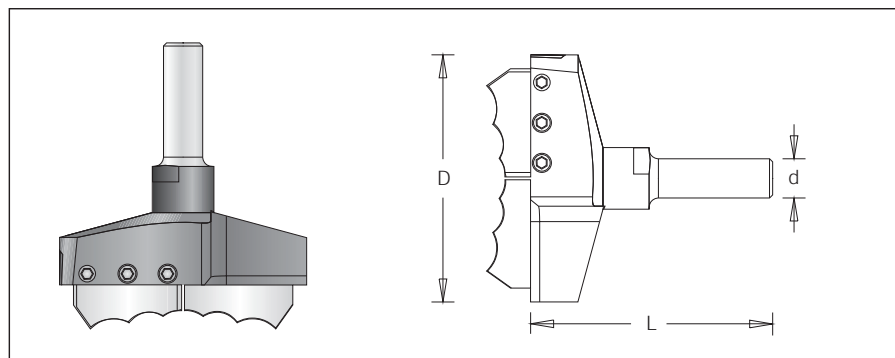

Sawing



CNC

	øD	Code No.	L	ød
Dirose	79.6	180 001 9	81	12

- ⚠ Check that the speed is suitable for the type of wood being worked
- MD F: 3000-6000 RPM
  - Soft Wood 3000-6000 RPM
  - Hard Wood 1500-2000 RPM

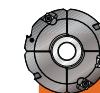

Cutting

## D irose™ Cutter

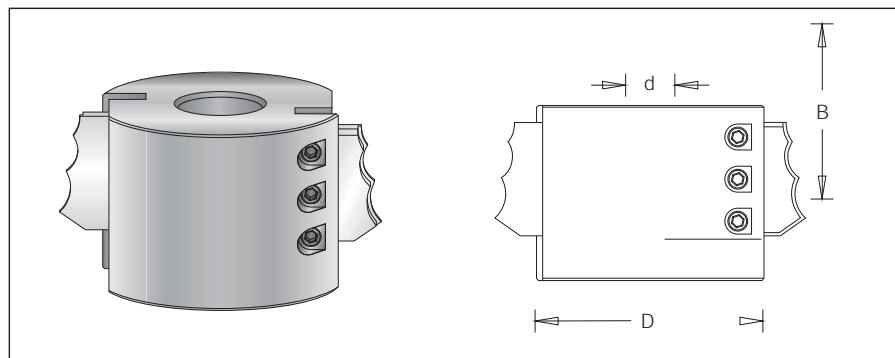

	øD	Code No.	B	ød
Dirose Cutter	74	180 002 1	54	30

- ⚠ Can be supplied with 5/8", 3/4" and 1".

### Spare Parts



Allen screw  
#193 065 0



Allen key  
1940090

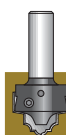

Routing



Plastic, Corian Aluminum

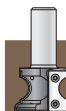

Custom Tooling



# D rilling

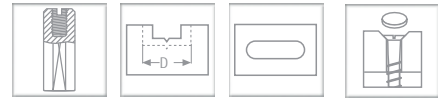

CNC & Automatic Machines    Multi Purpose Boring    Slot Mortising    Counter Sinking & Plug maker



## D irose™ Profile Shapes Available

1800010*	43	1800090	80
1800010	51	1800100	80
1800020*	50	1800100*	74
1800020	58	1800110	80
1800030	60	1800120	85
1800040	57	1800120*	77
1800050	70	1800130	90
1800060	70	1800130*	84
1800070	70	1800140	100
1800080	80	1800150	100



\* With this knife it is possible to execute both a depressed rosette in the wood and a protruding rosette (button) for gluing



Sawing



CNC



Cutting

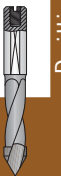

D rilling



Routing

Plastic, Corian, Aluminium

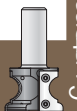

Custom Tooling